

IDENTIFY, MEASURE, CALCULATE ANGLES

Apply geometric concepts to model and solve real-world problems

Program Task: Diagnose cylinder head and valve train problems.

PA Core Standard: CC.2.3.HS.A.14

Description: Apply geometric concepts to model and solve real-world problems.

Program Associated Vocabulary:
DEGREES, DURATION, LIFT OVERLAP, TDC

Math Associated Vocabulary:
ANGLE, DEGREES, INTERIOR ANGLES, EXTERIOR ANGLES, VERTICAL ANGLES, CORRESPONDING ANGLES, PARALLEL, TRANSVERSAL

Program Formulas and Procedures:
When diagnosing cylinder head and valve train problems, the technician must determine: degrees, duration (time, measured in degrees a valve is open), lift (the maximum amount, measured in thousands of an inch a valve opens), and overlap (time measured in degrees of crankshaft rotation both intake & exhaust valves are open)

Formulas and Procedures:

Remember, in Automotive Technology, the top of a circle (TDC) is 0° whereas the top of a protractor is 90° .

Reading a protractor:

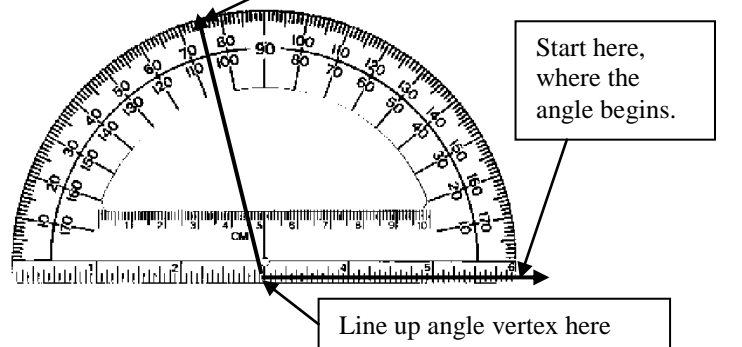

Example: Using the following specs, for a stock cam with smooth idle and good lower RPM torque, determine valve duration, and valve overlap.

Cam Timing: Tappet @.020		
Valve	Open	Close
Intake	21° BTDC	59° ABDC
Exhaust	61° BBDC	19° ATDC

Two parallel lines cut by a transversal:

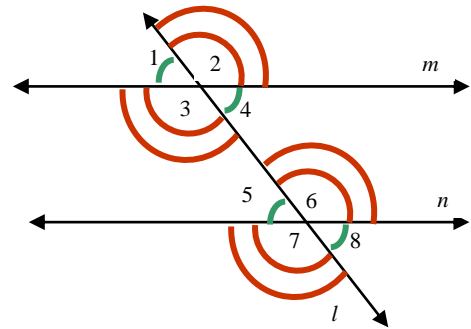

Angles **1&4, 2&3, 5&8, 6&7** are **vertical angles**.
Angles **1&5, 2&6, 3&7, 4&8** are **corresponding angles**.
If lines *m* and *n* are parallel then **corresponding angles** are congruent, **Alternate Interior** angles are congruent, and **Alternate Exterior** angles are congruent.
Vertical angles are always congruent.

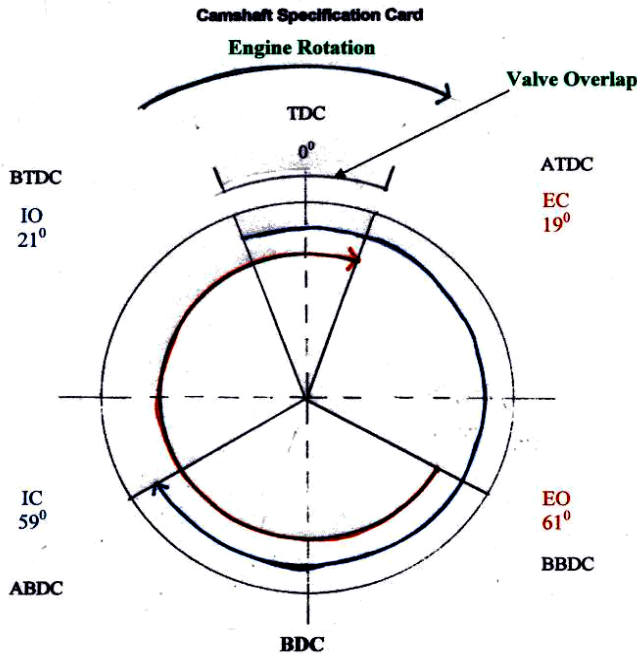

Examples:

- Intake valve duration: $21^{\circ} + 90^{\circ} + 90^{\circ} + 59^{\circ} = 260^{\circ}$
- Exhaust valve rotation: $61^{\circ} + 90^{\circ} + 90^{\circ} + 19^{\circ} = 260^{\circ}$
- Valve overlap: $21^{\circ} + 19^{\circ} = 40^{\circ}$

- If angle 1 = 40° , what is the measure of angle 8?
Angle 8 must measure 40° , since $\angle 1$ and $\angle 8$ are alternate exterior angles.
- If $m \angle 2 = 3x + 4$, and $m \angle 3 = x + 8$, solve for *x*.
(Vertical angles are equal.)
 $3x + 4 = x + 8$ (subtract *x* from both sides)
 $2x + 4 = 8$ (subtract 4 from both sides)
 $2x = 4$ (divide both sides by 2)
 $x = 2$

Automotive Technology (47.0604) T-Chart

Instructor's Script – Comparing and Contrasting

Most technical applications do not lend themselves to using a protractor. However, protractors can be used to explore, understand or even create technical scale drawings or models such as the valve charts above.

Alternatively, understanding the relative sizes of angles is certainly something students must understand if they are to clearly communicate what they have observed when troubleshooting or analyzing a situation. Protractors can be very useful when preparing students to understand the difference between very small angles (10°), medium angles (45° , 60°), acute angles (less than 90°), right angles (90°), or obtuse angles (larger than 90°).

In valve charts, you will notice the free use of TDC (top dead center) and BDC (bottom dead center) when referring to the angles. It is important to realize that when communicating sizes of angles, it is important to include such reference or orientation points which indicate where an angle starts and the direction to measure.

Common Mistakes Made By Students

- Not aligning the index line (line along the bottom of the protractor) with one side of the angle in question.
- Not placing the vertex of the angle at the hole or point at the bottom-center of the protractor.
- Not clearly specifying a reference or starting point for an angle.
- Reading the wrong indicator on the protractor (bottom number versus top number, or vice-versa).

CTE Instructor's Extended Discussion

Technical tasks are usually not presented using this model. Therefore, it is important that technical instructors demonstrate to students how these math concepts link to and are relevant in their technical training and that the math is presented in a way which shows a relationship to the math which CTE students use in their academic school settings.

This T-Chart focuses on valve timing calculations as an example of formulas used by automotive technology professionals especially in speed shops and custom engine builders.

ITEMS NEEDED FOR PAGE #3:

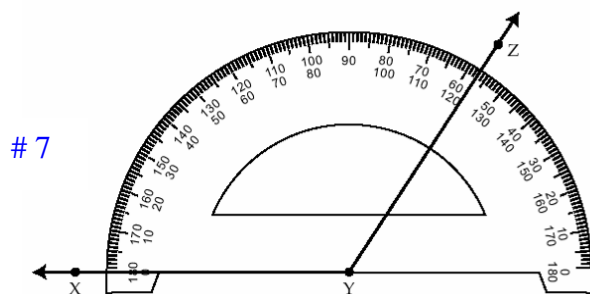
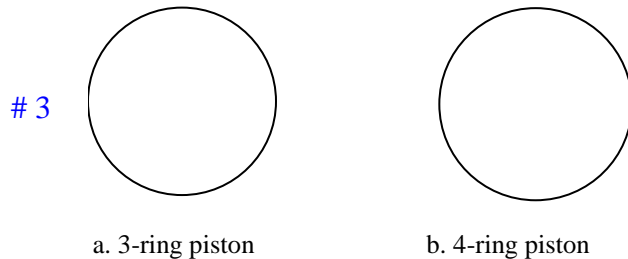

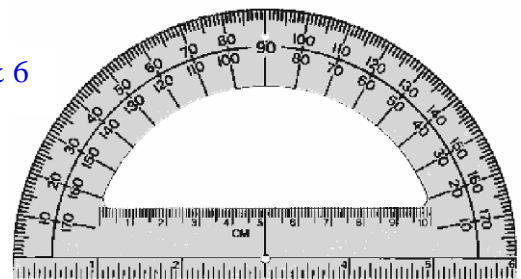

5 & 6

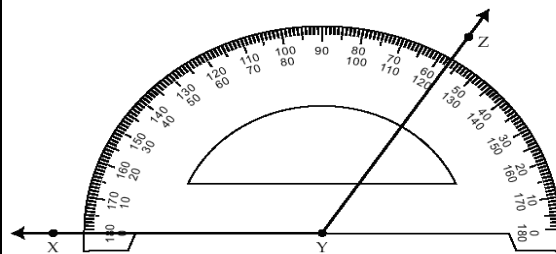
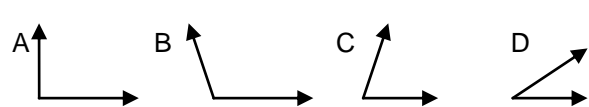
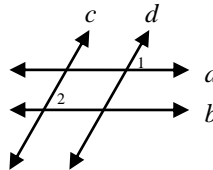

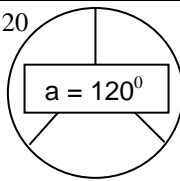
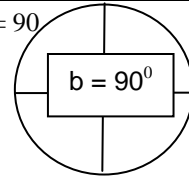
Problems	Career and Technical Math Concepts	Solutions												
<p>1. Complete: Daily Use (Stock) Camshaft Specification Card if ...</p> <table border="1"> <tr> <td colspan="3">Cam Timing: Tappet @.020</td> </tr> <tr> <td>Valve</td> <td>Open</td> <td>Close</td> </tr> <tr> <td>Intake</td> <td>14° BTDC</td> <td>66° ABDC</td> </tr> <tr> <td>Exhaust</td> <td>64° BBDC</td> <td>16° ATDC</td> </tr> </table>	Cam Timing: Tappet @.020			Valve	Open	Close	Intake	14° BTDC	66° ABDC	Exhaust	64° BBDC	16° ATDC		
Cam Timing: Tappet @.020														
Valve	Open	Close												
Intake	14° BTDC	66° ABDC												
Exhaust	64° BBDC	16° ATDC												
<p>2. Complete: Daily Use (Stock) Camshaft Specification Card if ...</p> <table border="1"> <tr> <td colspan="3">Cam Timing: Tappet @.020</td> </tr> <tr> <td>Valve</td> <td>Open</td> <td>Close</td> </tr> <tr> <td>Intake</td> <td>41° BTDC</td> <td>87° ABDC</td> </tr> <tr> <td>Exhaust</td> <td>89° BBDC</td> <td>47° ATDC</td> </tr> </table>	Cam Timing: Tappet @.020			Valve	Open	Close	Intake	41° BTDC	87° ABDC	Exhaust	89° BBDC	47° ATDC		
Cam Timing: Tappet @.020														
Valve	Open	Close												
Intake	41° BTDC	87° ABDC												
Exhaust	89° BBDC	47° ATDC												
<p>3. To reduce engine blow-by (gases leaking past the piston rings) the gaps on the piston ring should be evenly spaced. On a typical 3-ring piston the gaps would be (a) _____^o apart & (b) _____^o apart on a 4-ring piston. Complete using diagrams provided on page 2 of the T chart.</p>														
Problems	Related, Generic Math Concepts	Solutions												
<p>4. Which angle would you estimate to be the interior angle of the hairpin shown here? How would you describe a "hairpin turn" in the road?  a) 10° b) 30° c) 45° d) 90°</p>														
<p>5. Your GPS indicates that you are traveling in a direction (bearing) that is determined to be 270°. If 90° is east, in which direction are you traveling?</p>														
<p>6. To be wheelchair accessible, the grade of a ramp must not exceed 1 foot of rise per 12 feet of run. This equates approximately to a 5° angle. Use the protractor provided to draw this angle measure.</p>														
Problems	PA Core Math Look	Solutions												
<p>7. What is the angle measure of $\angle XYZ$?</p> <p>a) 57° b) 63° c) 123° d) 137°</p>														
<p>8. Which of the angles on the right is closest to 76°?</p>														
<p>9. Given: $a \parallel b$, $c \parallel d$ If $m\angle 1 = 2x + 16$ and $m\angle 2 = x + 18$, then what is the value of x?</p>														

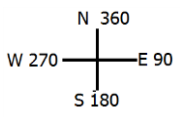
Problems	Occupational (Contextual) Math Concepts	Solutions												
1. Complete: Daily Use (Stock) Camshaft Specification Card if ... <table border="1" style="margin-left: 20px;"> <tr> <td colspan="3">Cam Timing: Tappet @.020</td> </tr> <tr> <td>Valve</td> <td>Open</td> <td>Close</td> </tr> <tr> <td>Intake</td> <td>14° BTDC</td> <td>66° ABDC</td> </tr> <tr> <td>Exhaust</td> <td>64° BBDC</td> <td>16° ATDC</td> </tr> </table>	Cam Timing: Tappet @.020			Valve	Open	Close	Intake	14° BTDC	66° ABDC	Exhaust	64° BBDC	16° ATDC		1. Intake Valve Duration: $14^0 + 90^0 + 90^0 + 66^0 = 260^0$ 2. Exhaust Valve Duration: $64^0 + 90^0 + 90^0 + 16^0 = 260^0$ 3. Valve Overlap: $14^0 + 16^0 = 30^0$
Cam Timing: Tappet @.020														
Valve	Open	Close												
Intake	14° BTDC	66° ABDC												
Exhaust	64° BBDC	16° ATDC												
2. Complete: Daily Use (Stock) Camshaft Specification Card if ... <table border="1" style="margin-left: 20px;"> <tr> <td colspan="3">Cam Timing: Tappet @.020</td> </tr> <tr> <td>Valve</td> <td>Open</td> <td>Close</td> </tr> <tr> <td>Intake</td> <td>41° BTDC</td> <td>87° ABDC</td> </tr> <tr> <td>Exhaust</td> <td>89° BBDC</td> <td>47° ATDC</td> </tr> </table>	Cam Timing: Tappet @.020			Valve	Open	Close	Intake	41° BTDC	87° ABDC	Exhaust	89° BBDC	47° ATDC		1. Intake Valve Duration: $41^0 + 90^0 + 90^0 + 87^0 = 308^0$ 2. Exhaust Valve Duration: $89^0 + 90^0 + 90^0 + 47^0 = 316^0$ 3. Valve Overlap: $41^0 + 47^0 = 88^0$
Cam Timing: Tappet @.020														
Valve	Open	Close												
Intake	41° BTDC	87° ABDC												
Exhaust	89° BBDC	47° ATDC												
3. To reduce engine blow-by (gases leaking past the piston rings) the gaps on the piston ring should be evenly spaced. On a typical 3-ring piston the gaps would be (a) ____° apart & (b) ____° apart on a 4-ring piston. Complete using diagrams provided on page 2 of the T chart	$360/3 = 120$ 	$360/4 = 90$ 												

Problems	Related, Generic Math Concepts	Solutions
4. Which angle would you estimate to be the interior angle of the hairpin shown here? How would you describe a “hairpin turn” in the road? a) 10° b) 30° c) 45° d) 90° 		The correct answer is “a” because a 10° interior angle turn would very nearly turn a driver back in the direction from which s/he came. Hairpin turns get their name because they have interior angles similar to a real hairpin.
5. Your GPS indicates that you are traveling in a direction (bearing) that is determined to be 270°. If 90° is east, in which direction are you traveling? 		You are traveling West (when your bearing is 270°) 90° is East, 180° is South, and 360° is North.
6. To be wheelchair accessible, the grade of a ramp must not exceed 1 foot of rise per 12 feet of run. This equates approximately to a 5° angle. Use the protractor provided to draw this angle measure.		This is what the angle should resemble if drawn by a protractor. 

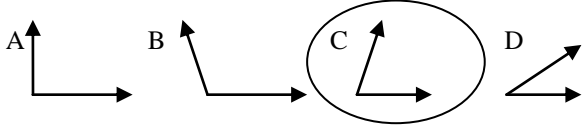
Problems	PA Core Math Look	Solutions
7. What is the angle measure of ∠ XYZ? a) 57° b) 63° c) 123° d) 137°		c.) 123°
8. Which of the angles on the right is closest to 76°?		
9. Given: $a \parallel b, c \parallel d$ If $m \angle 1 = 2x + 16$ and $m \angle 2 = x + 18$, then what is the value of x?		Angles 1 and 2 are congruent angles so, $2x + 16 = x + 18$ $x + 16 = 18$ $x = 2$ (subtract x from each side, then subtract 16 from each side)